

Neptune

Hang Do, EE, Scott Powell, EE, and Frankie Viscusi, EE

Abstract—Unauthorized entry into residential swimming pools is a concerning issue which in many cases can lead to property damage, injury liabilities, or even death. The Neptune system will address this issue by constantly monitoring the pool environment for signs of intrusion. Utilizing Passive Infrared (PIR) sensors and audio analysis (microphone), Neptune will monitor the current risk associated with the pool. The PIR sensor will constantly monitor for people and animals that cross its field of view. The microphone will be listening to all sounds, and using machine learning and signal processing algorithms identify when splash sounds occur. This twofold detection system will produce accurate results with a low probability of false alarms. When the pool is determined to be at risk (PIR sensor is tripped and a splash sound is detected), poolside alarms will sound and the user will receive a Multimedia Messaging Service (MMS) notification with a warning message and a picture of the pool environment.

I. INTRODUCTION

In a day and age when security is on the forefront of every property owner's mind, one area that has remained largely unprotected and vulnerable is the backyard. The backyard poses a significantly increased liability for homeowners with a pool, as drowning ranks 5th in the leading causes of unintentional injury death in the United States and is the 1st among children aged 1-4. From 2005-2009, there were an average of 3,900 drowning deaths per year in the U.S. Approximately half of these deaths occurred in unsupervised swimming pools [1].

Pools are particularly problematic due to their ability to attract children and teenagers to break into one's yard to go swimming, otherwise known as "pool-hopping". Despite the illegality of pool-hopping, the owner may still be at fault for any injury or drowning that occurs while any child is using the pool. The legislature that governs this situation is known as the Attractive Nuisance Doctrine. It states that, "a landowner may be liable for injuries to children who trespass on land if the

injury results from a hazardous object or condition on the land that is likely to attract children who are unable to appreciate the risk posed by the object or condition" [2]. Not only does the Neptune system deter people from participating in pool hopping, it also aims to alert parents in the event a child enters the pool. Both of these scenarios could lead to accidental drowning and unintentional death. Neptune directly helps to prevent the tragic fallout parents experience after a child's death, as well as aiming to curb the attractiveness of pool hopping.

In the past, pool alarm systems have sought to protect pools by utilizing audible alarms to alert those nearby of a possible intrusion. Current designs on the market include both underwater and above water variations. Unfortunately, those located above the surface tend to cause frequent false alarms as they fail to consider false alarms from environmental stimuli. Those placed beneath the water provide enhanced reliability, but are also more expensive. The Neptune system improves upon what is currently on the market and takes intrusion detection to the next level. Upon detection, Neptune will send a text message with photo to registered phones. Most current pool monitoring solutions only alert those nearby the pool to a potential intrusion. Table 1 includes a list of goals and our final product specifications.

TABLE I
SPECIFICATIONS

Specification	Goal	Actual
PIR Sensing Range	10.25ft. 120° view	One PIR covers Inflatable children's pool (60 x 60 x 13 in)
Weight	< 7lbs	7lbs
Power consumption (DC)	< 50 W	36 W
Alarm Decibel Level	> 30 decibels	70 decibels
Weatherproof	Watertight	Sheltered
MMS Message Sent Time	< 1 minute	< 1 minute
Alarm/Floodlight Response Time	Immediately upon splash detection	Immediately upon splash detection

H. Do from Boston, Ma (e-mail: ttdo@umass.edu).

S. Powell from Berkley, Ma (e-mail: spowell@umass.edu).

F. Viscusi from North Attleboro, Ma (e-mail: fviscusi@umass.edu).

II. DESIGN

A. Overview

Neptune will be our solution to the problem of detecting an unauthorized entry into a residential swimming pool. To achieve this goal, we will utilize the PIR sensors to read changes in temperature in the surrounding area, providing us the earliest detection of a warm body entering the pool area. The rationale for using PIR is that it has the ability to sense humans and/or animals, while not detecting inanimate objects such as balls, rocks, and others. In addition to the sensors around the swimming pool, we also include a stationary microphone located above the water surface to constantly record the surrounding sounds. The sensitivity of both PIR sensor and microphone will be adjusted depending on the weather.

A single board computer will receive all recorded sounds coming from the microphone and use a machine learned audio classifier to determine if a splash has occurred recently in the pool area. If our classifier determines that an incoming audio segment contained a splash, the camera would take photos of the pool environment. Furthermore, we will utilize a floodlight to make sure that the captured pictures are recognizable even during the nighttime.

Once the motion is detected by the PIR sensor and a splash has occurred, the Raspberry Pi will take picture of pool environment (with floodlight illuminated), send an MMS text message within one minute, and activate the alarm system. Due to the cost considerations and complexities involved with using cellular chip, we decided to utilize a N150 Wi-Fi Nano USB Adapter [3] as opposed to 4G/LTE to send MMS messages from Gmail account to registered phones. Shown in Figure 1 is the overall block diagram of the Neptune system.

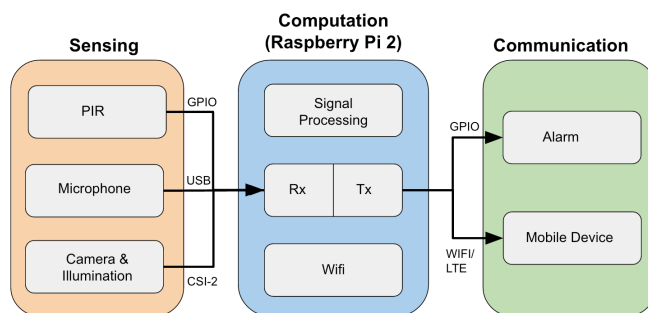

Figure 1: Block Diagram of Neptune system

B. Block 1: Passive Infrared (PIR) Sensor

The goal of the PIR sensor subsystem [4] is to detect physical, living entities by sensing temperature that enter the area immediately adjacent to the pool. So when a person or an animal is detected, we expect a high voltage signal of approximately 2.88V to be applied to the Raspberry Pi I/O, and 0V otherwise as shown in Fig. 2. We decided that a standard PIR sensor would be the simplest, least power consuming, and most cost effective way to accomplish our goals.

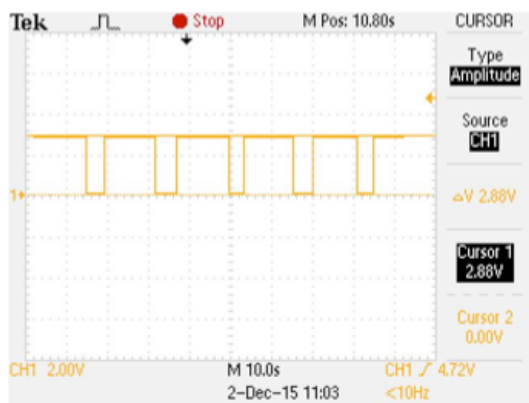

Figure 2: Output of PIR displayed on Oscilloscope

The essential characteristics that a PIR sensor must exhibit in order to be used in our system are good range and a wide field of view. We performed an experiment in order to test these characteristics. First, we supplied 5V as an input voltage and wired the output of PIR sensor in series with a 220Ω resistor and an LED. An LED will illuminate when a person or animal is detected. This circuit was placed on a park bench approximately two feet off the ground. We then walked to several different distances on each side of the PIR sensor (x

direction) and then proceeded forward (y direction) to the point where the PIR sensor detected our presence. We recorded this point and performed a series of calculations to determine the range and field of view of the sensor. A chart showing the results of this experiment is represented below.

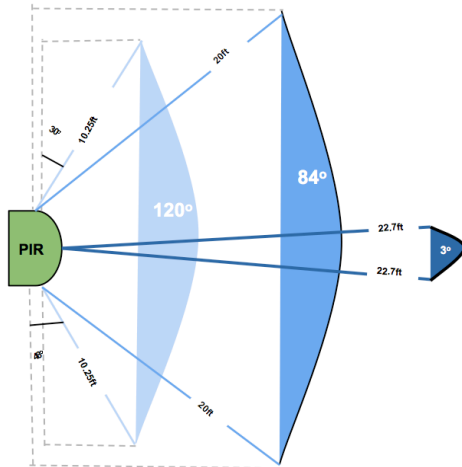

Figure 3: PIR Sensitivity

Analyzing the results of the test shows that the PIR sensor has a 120° field of view but the range is significantly less toward the edges of this field (10 feet) as opposed to directly in front of the sensor (20 feet). PIR will detect any object within 20 ft for an 84° scope (70% of field) and any object within 10 ft for the entire 120° field of view. Knowing this information is important because we will use it to determine the number of sensors, their location, and orientation necessary to maximize our effective detection area.

C. Block 2: Machine Learning & Audio Analysis

Coupled with the PIR sensor is a microphone [5] that aids in the detection of an unauthorized entry into the swimming pool area. The main purpose of this block is to determine when a drowning risk actually occurs, and then a set of mobile phone numbers which the user registered will be alerted to the threat. To achieve this goal, the microphone constantly records sounds coming from the pool environment. An analysis of the audio sample is then done to determine if it is likely that a splash occurred. Below is a spectrogram analysis of a sample splash sound in a normal pool environment.

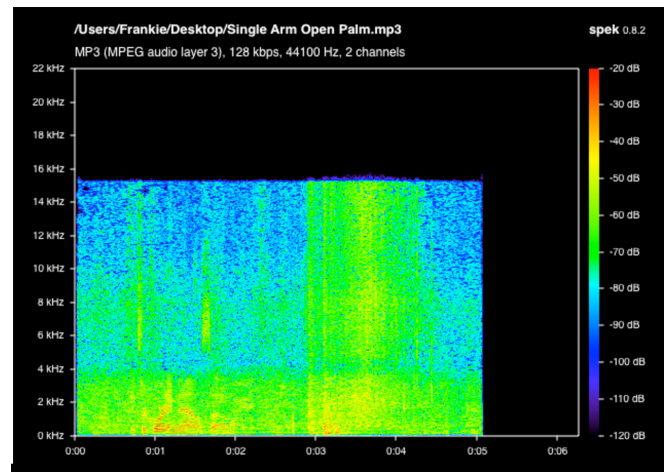

Figure 4: Spectrogram Analysis of a sample Splash sound

The audio sample used in the spectrogram was recorded at the Totman swimming pool. For this particular trial, a splash was produced by hitting the surface of the water with a single arm and open palmed hand. In this short clip, the first three seconds represent time before the splash occurred. Here, you can see that the recording device picked up spoken words between 0:01 and 0:02 seconds. This corresponds with someone instructing our team member to begin the splash. At 0:03 seconds, the swimmers' arm first made contact with the water. This is represented in the spectrogram by the sudden increase in frequency sound from 4 kHz to 15 kHz. With this information in mind, our goal is to separate splash sounds from background noise and use that with the PIR sensor to determine with reasonable certainty that there has been an unauthorized intrusion and to alert the Neptune system administrators.

Using this data, it was determined that detecting splash sounds was possible. We decided the best way to accomplish this task was to train an audio classifier to detect splashes. This method will result in less false alarms as opposed to a hard-coded algorithm based on frequency and amplitude that correspond to a splash. To achieve this goal, the microphone constantly records seven-second sound segments coming from the pool environment. Utilizing the python library PyAudioAnalysis and its audio feature extraction capabilities and machine learning algorithms, Neptune uses machine learning in order to achieve an accurate splash detection system.

In order to train the audio classifier, hundreds of experimental splash sounds were recorded from various water sources (inflatable children’s pool, bucket, etc.). Then, these .WAV sound files were placed into “splash” and “non-splash” folders and used to train a KNN audio classifier. Each seven-second sound segment of audio is then fed into this classifier where it gives its decision on if the given audio segment is a splash or not based on the audio features extracted during the training process. Our constantly recorded audio clips will be fed into the classifier we trained with experimental “splash” and “non-splash” data. The classifier then gives its decision on if the given audio segment is a splash or not based on the audio features extracted during the training process. At this point if the latest audio segment is determined to be a “splash” sound, the system will see if the PIR sensor has been triggered recently. If both methods of detection are in a positive state, the picture of the pool will be taken, the message will be sent to the user's phone, and a pool-side alarm will sound.

D. Block 3: MMS Messaging

After the audio signal is processed and the PIR senses a human or an animal, it comes the task of relaying the information to the homeowner. We communicate by sending an MMS message from a dedicated Gmail account to the email address or phone number desired by the homeowner. Contained in the MMS message is a generic alert indicating that the Neptune system has been triggered and a picture of the pool will be attached for the homeowner to confirm the alert.

The first step in setting up the alert system is to record the user’s information into the Raspberry Pi 2 Model B [6]. The Graphical User Interface (GUI) used in this system (Figure 5) was created using Tkinter, a GUI library native to Python. The goal of establishing the interface is to make it accessibly simple for people with minimal computer experiences to operate. The GUI contains one text field for entering the phone number or email address as well as a selection field to choose the user’s mobile provider. Upon the user inputting his/her information and pressing the “Update” button, the data is formatted to be read later and

saved to the Raspberry Pi. The last button within the GUI is the “Log” button, which displays a list of all the alerts sent from the Raspberry Pi.

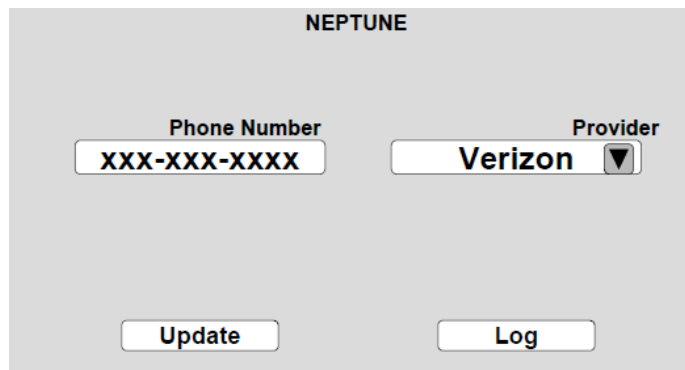

Fig. 5. Graphical User Interface

Upon detecting an unauthorized entry, Neptune retrieves the data which the user saved as well as the picture captured at the corresponding time to the alert. Neptune then connects to the Gmail servers through a Wi-Fi connection and logs into the assigned Gmail account. After compiling the message from its pieces: the owner’s information, the body consisting of the generic alert and the picture, Neptune sends the message to the user; thus completing the alert process. If an error is encountered at any point in the messaging process, Neptune would still save the alert and error message into the log, and then proceed to activate the alarm system. An example MMS message that Neptune deploys is shown in Figure 6.

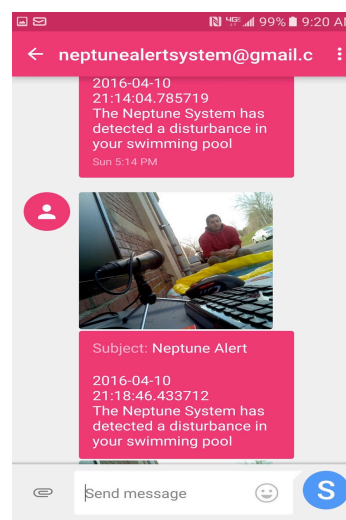

Fig. 6. Example of Neptune Text Message

E. Block 4: Alarm System

In addition to sending an MMS message to the homeowner, Neptune will also activate an audible alarm located poolside to alert those nearby. Neptune alarm system is supplied by 12V and could produce up to 70 dB. In order to integrate the alarm system into Neptune, we utilized EDR201A0500 relay [7] to serve as a switch, which will be triggered by the Raspberry Pi GPIO PIN11 as both a splash was detected and the PIR indicated “high”. To accomplish the goal of designing a high-decibel alarm, we chose the LM384 Audio Amplifier [8] to increase the power that successfully drives our 15W speaker horn [9].

The complete PSPICE schematic and protoboard of our Neptune alarm system are shown in Appendix I and Fig. 7. Besides the audio amplifier, what also drive the speaker and an LED are the complementary feedback pair known as a Sziklai Pair and a frequency generator circuit.

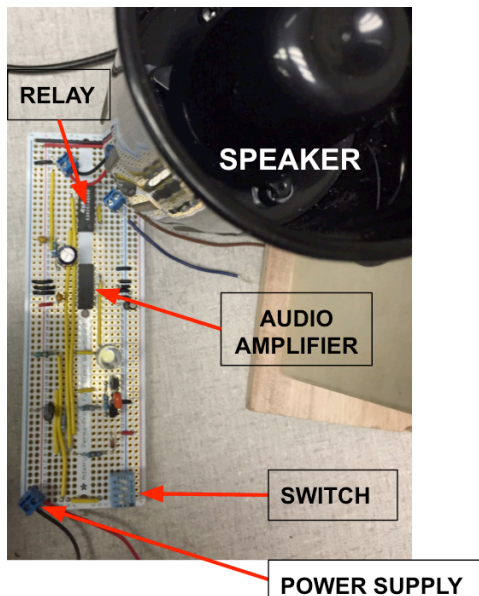

Figure 7: Protoboard Neptune Alarm System

The Sziklai Pair is the cascaded combination of 2N3906 (PNP) [10] and 2N3904 (NPN) [11] transistors to provide a higher current gain of β^2 . The Base of this pair will be driven by a frequency generator circuit consisting of a series of C1, C2, and R3. We utilized the momentary push-button switch to activate the alarm so that once the switch is on, the two capacitors will be charged and the

Sziklai Pair will be in the “active” mode. The response time of the switch is controlled by $10\mu\text{F}$ capacitor (C2) while the sound wave of the speaker is generated by a 3.3nF capacitor (C1).

F. Block 5: Power System

The two main requirements for the power system are to provide 12V-3.5A to supply the alarm system and 5V-2A to power the Raspberry Pi. The primary source of our power system is the wall outlet carrying a voltage of 120VAC, which is then stepped down to 12V-3.5A by an AC/DC Adapter [12] to feed into our alarm system. Due to the simplicity, low cost, high efficiency, and TTL shutdown capability, we chose LM2576 [13] as our switching voltage regulator to reduce 12V to 5V in order to power the Raspberry Pi. The overall power system block diagram is shown in Figure 8. Sharing the same standard 120VAC outlet is the floodlight. We utilized the relay module supplied by 5V from the Raspberry Pi to switch on the floodlight as an intrusion was detected.

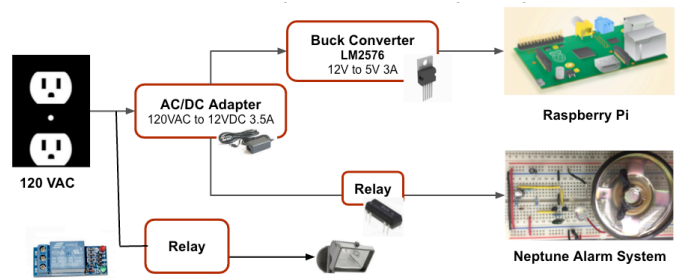

Fig. 8. Power System Block Diagram

Figure 9 is the LM2576 schematic to produce a fixed output voltage of 5V. The result of the step-down voltage regulator is shown in the Figure 10. The leftmost terminal block is supplied by 12V-3.5A AC/DC adapter and the second terminal block outputs 5.044V.

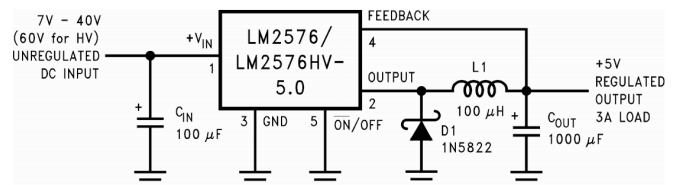

Fig. 9. LM2576 Voltage Regulator Schematic

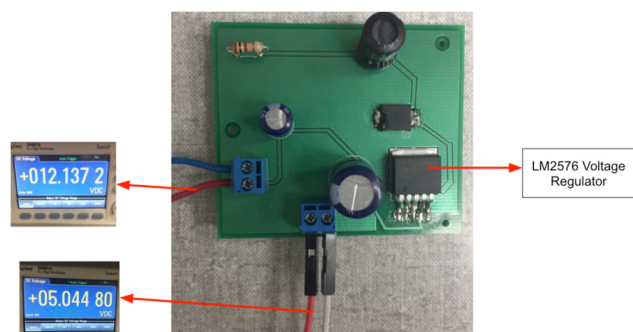

Fig. 10. PCB Voltage Regulator

G. Block 6: Camera & Illumination

Neptune incorporates a camera and floodlight in order to capture unexpected intrusions in a swimming pool. The camera chosen was the Raspberry Pi Camera due to its native integration with the Raspberry Pi 2. The camera interfaced with the board through a CSI-2 serial interface. When an intrusion is detected, the camera captures a photo of the pool area and the Raspberry Pi includes this image in the text message alert sent to the subscribed phone number [14].

Accompanying the camera is a Lithonia Lighting OFLM 150Q 120 LP BZ M12 floodlight, which is shown attached to Neptune in Image 1 [15]. It is intended to illuminate the pool area in the event of nighttime pool intrusions. When a splash is detected, the floodlight turns on and remains on until the situation is resolved by the homeowner. Our chosen model was retrofitted with a plug housing in order to be powered by a standard 120V electrical outlet. An independently powered relay package was used to interface with the Raspberry Pi 2 to allow the 3.3V from a dedicated GPIO pin 07 to turn on and off the floodlight. The 5V required to power this relay package came from a 5V pin on the Raspberry Pi 2. The relay bundled with this package is the Songle SRD-05VDC-SL-C relay, which can accommodate up to 10A, 250V AC [16]. This floodlight contained a single 150W halogen light bulb, which proved sufficient for illuminating the area captured by the Raspberry Pi Camera.

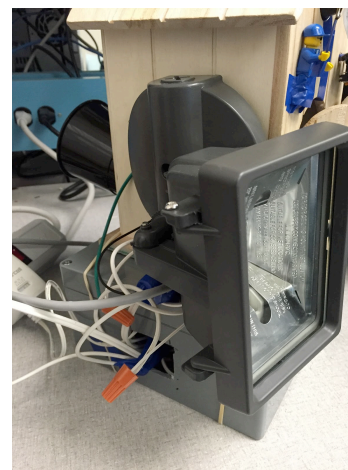

Image 1

III. PROJECT MANAGEMENT

Although there were some setbacks, Neptune progressed roughly according to schedule and was ready for demo day on Friday, April 22nd 2016. Our biggest setback came from the loss of our fourth team member, who was in charge of MMS message communications and related software on the Raspberry Pi. Fortunately, we were able to fill in the gap that was left behind and get all of the necessary work done in order to have a working project by demo day.

One aspect of our project that was affected by the loss of our team member was the inclusion of an integrated camera flash. Following the Midyear Design Review, our goal for final implementation included a dedicated flash that would trigger only when photos were being taken by the Raspberry Pi 2 camera. With one less set of hands, we decided that we would forgo the dedicated flash and opted to instead use a floodlight that would trigger on in the event of a splash detection. This ended up being a wise choice for us, as we were able to simplify our design while also maintaining the core functionality of the flash illumination.

As a team, we were able to overcome our obstacles and work together to build something that we were proud of. Our dynamic was still strong continuing into the second semester. Ultimately, our original timeline and

responsibilities shifted as we reallocated tasks amongst the members of our smaller team. Scott took over the software aspect of Neptune while Hang focused on the alarm and Frankie worked with the floodlight. At this time, we have no plans to continue working with Neptune, however we recognize the potential that this project has for future optimization and commercialization.

IV. RESULTS

Objects	At 4ft	At 7ft	At 10ft
Big Rock (5.8 lb)	Yes	Yes	Yes
Black Metal (3.3 lb)	Yes	Yes	Yes
Little Rock (1.3 lb)	Yes	Yes	Yes
Black Spring (0.8 lb)	Yes	Yes	No
False Positives	2	2	1
7-second Samples	97	85	34.56
False Positives	2.06%	2.35%	2.89%

Our final prototype of Neptune met all of our major specification goals and has proven to be an effective as a pool security and drowning defense system. The system is capable of detecting people and/or splashes and sending messages within a minute of detection. As seen in the table, the Neptune system was able to detect the majority of splash sounds that occurred at varying distances. The performance of the classifier depended on the distance of the system from the source of the splash, the weight of the object being thrown in, and the amount of other noises occurring in the background. As expected, the performance improved the closer the splash was to the system. However, even at 10 feet away, a splash could still be detected except for the very lightest object. We noticed that introducing background noise does results in reduced performance because most our training was performed in settings with little to no noise to interfere with sound collection. Throughout our testing, our system produced very little false alarms rate. Only two percent of all decisions made by the classifier resulted in false positives.

V. CONCLUSION

On the Senior Design Project Demo day, we successfully demonstrated to the faculties, staffs, students, and guests the functionality of our subsystems individually, and the system as a whole. The PIR sensor detected heat signatures at a decent range as we described in Figure 3. The message with a picture of an intrusion attached was sent to a cell phone in less than a minute via Wi-Fi. Neptune alarm system was loud and produced an appropriate tone, along with the floodlight being fully integrated and switched on as a splash was detected and the PIR indicated “high”. We have also tackled the power issues that we came across after the Midway Design Report (MDR) by utilizing the AC/DC Adapter and a switching voltage regulator.

One of the main problems we have encountered was the splash classification; false positive readings often occurred. After receiving feedbacks from our evaluator, Professor Parente, who is very experienced in machine learning, we realized that training 30 to 40 samples collected from an children’s pool and a bucket filled with water was not enough for the machine learning, PyAudioAnalysis, to differentiate the “splash” and “non-splash”. Thus, we decided to record more than 300 samples continuously and classify each into “splash” and “non-splash” categories. As a result, our sound classification has enhanced tremendously and was able to detect splashes due to a 0.8lb object outdoors from 7ft away with the microphone.

Overall, we have learned a lot throughout this academic year building and designing Neptune. We were able to utilize our resourceful experience and academic skills to tackle all the problems that came along the way. All four presentations provided us opportunities to review our progress periodically based on our evaluators’ feedbacks, and decide the new paths to improve Neptune.

ACKNOWLEDGMENT

First and foremost, we would like to thank our faculty advisor, Professor Holcomb for his support and guidance throughout the first half of our SDP project. Secondly, we want to thank our evaluators Professor Parente and Professor Vouvakis for their

honest and valuable feedback. Lastly, we want to give thanks to Professor Hollot and Francis Caron, who both work to make this course a possibility.

APPENDIX I

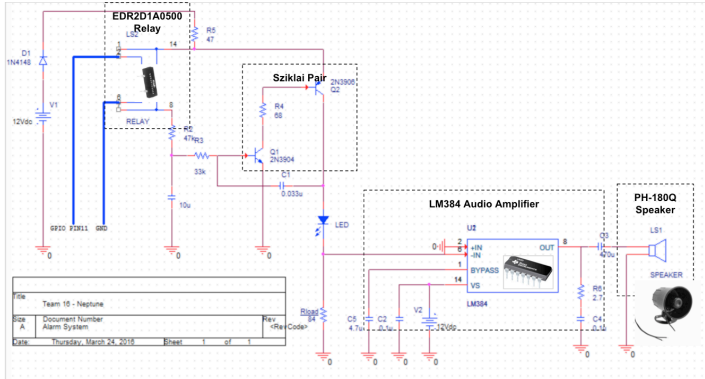

- [13] Texas Instruments. (2013, Apr). *LM2576/LM2576HV Series SIMPLE SWITCHER® 3A Step-Down Voltage Regulator* [Online]. Available: <http://www.ti.com/lit/ds/symlink/lm2576.pdf>. [Accessed: 06- May-2016].
- [14] A. Industries. (n.y., n.d.). *Raspberry Pi Camera Board* [Online]. Available: <https://www.adafruit.com/products/1367> [Accessed: 22-Jan-2016]
- [15] "Lithonia Lighting 1-Head Mini Bronze Outdoor Flood Light-OFLM 150Q 120 LP BZ M12 - The Home Depot", *The Home Depot*, 2016. [Online]. Available: <http://www.homedepot.com/p/Lithonia-Lighting-1-Head-Mini-Bronze-Outdoor-Flood-Light-OFLM-150Q-120-LP-BZ-M12/100652891>. [Accessed: 06- Apr- 2016].
- [16] "Relay for Raspberry Pi or Arduino 1-Channel 5V Relay Module 250V/10A", *Ha.privateeeyepi.com*, 2016. [Online]. Available: http://ha.privateeeyepi.com/store/index.php?route=product/product&product_id=74. [Accessed: 06- May- 2016].

REFERENCES

- [1] CDC. (2012, May 18). *Drowning – United States, 2005-2009* [Online]. Available: <http://www.cdc.gov/mmwr/preview/mmwrhtml/mm6119a4.htm> [Accessed: 20-Dec-2015]
- [2] Cornell University Law School (n.y., n.d.). *Attractive Nuisance Doctrine* [Online]. Available: https://www.law.cornell.edu/wex/attractive_nuisance_doctrine [Accessed: 22-Jan-2016]
- [3] EDIMAX. (2015, n.d.). *N150 Wi-Fi Nano USB Adapter, Ideal for Raspberry Pi* [Online]. Available: http://www.edimax.com/edimax/merchandise/merchandise_detail/data/edimax/global/wireless_adapters_n150/ew-7811un [Accessed: 22-Jan-2016]
- [4] A. Industries. (n.y., n.d.). *PIR (motion) sensor* [Online]. Available: <https://www.adafruit.com/products/189> [Accessed: 22-Jan- 2016]
- [5] CAD. (2007, Oct 1). *CAD U1 USB Dynamic Recording Microphone* [Online]. Available: <http://www.amazon.com/CAD-U1-Dynamic-Recording-Microphone/dp/B000ULQTE0> [Accessed: 22-Jan-2016]
- [6] Raspberry Pi Foundation. (n.y, n.d.). *Raspberry Pi 2 Model B* [Online]. Available: <https://www.raspberrypi.org/products/raspberry-pi-2-model-b/> [Accessed: 22-Jan- 2016]
- [7] MOBICON Electronic Components. (2016, n.d.). *EDR Series* [Online]. Available: <http://www.mantech.co.za/datasheets/products/EDRXXX.pdf>. [Accessed: 06- May- 2016].
- [8] Texas Instruments. (2013, Apr). *LM384 5W Audio Power Amplifier* [Online]. Available: <http://www.ti.com/lit/ds/symlink/lm384.pdf>. [Accessed: 06- May- 2016].
- [9] Malloy Sonalert Products Inc. (n.y., n.d.). *PH-180Q* [Online]. Available: <http://www.mallory-sonalert.com/specifications/PH-180Q.PDF>. [Accessed: 06- May- 2016].
- [10] ON Semiconductor. (2010, Feb). *2N3906 General Purpose Transistors PNP Silicon* [Online]. Available: http://www.onsemi.com/pub_link/Collateral/2N3906-D.PDF. [Accessed: 22-Jan-2016]
- [11] ON Semiconductor. (2010, Feb). *2N3903, 2N3904 General Purpose Transistors NPN Silicon* [Online]. Available: http://www.onsemi.com/pub_link/Collateral/2N3903-D.pdf [Accessed: 22-Jan-2016]
- [12] Amazon. (2016, n.d.). *12 Volt Power Supply – 3.5 Amp Standard (12V 3.5A DC) Adapter* [Online]. Available: <http://www.amazon.com/12-Volt-Power-Supply-Standard/dp/B009ZZPOCK>. [Accessed: 06- May-2016].